

Revision Level			Revision Record	Changed	Date	Approved	Date
Drawing	State	Part					
06.1	Design Release	A	SEE ECN# 013477	EJF	5/16/16	KVH	5/16/16

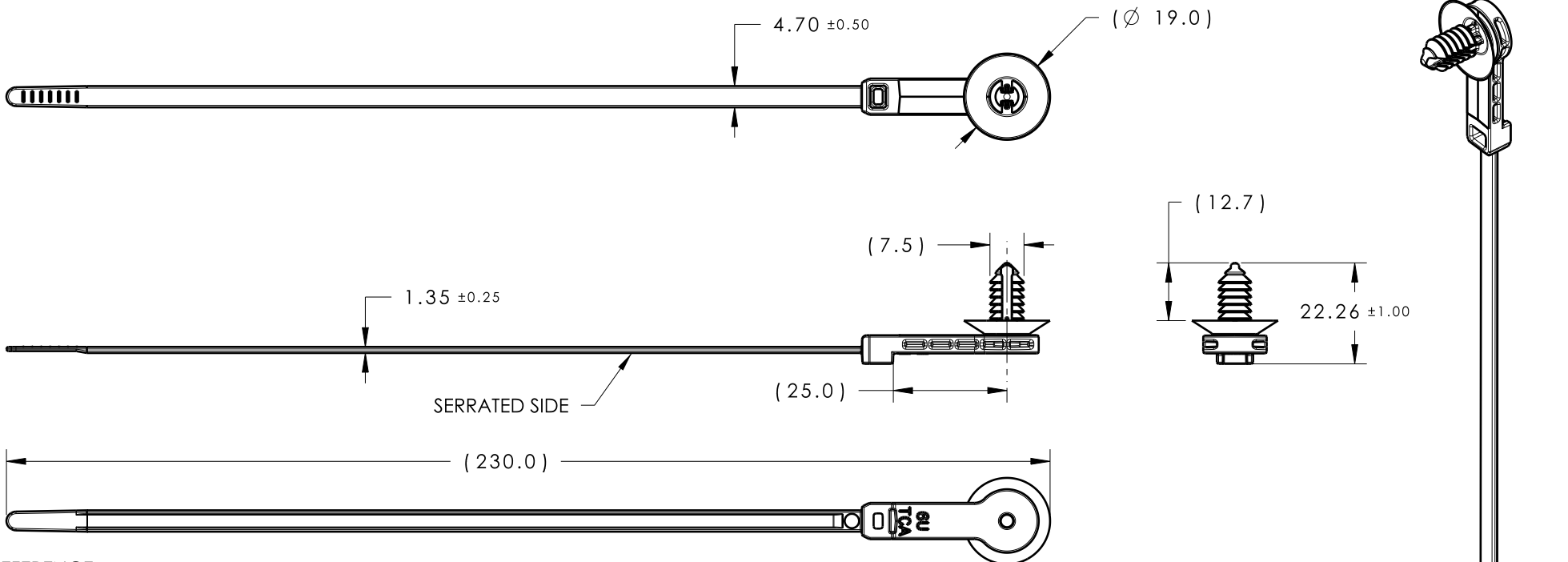

- REFERENCE:
 PERFORMANCE REQUIREMENTS AT DRY AS MOLDED:
1. FIR TREE PUSH IN FORCE: 45 NEWTONS (10 LBS) MAX IN THE APPLICABLE NOMINAL HOLE SIZE AND A PLATE THICKNESS OF 1.8mm.
 2. FIR TREE PULL OUT FORCE: 110 NEWTONS (25 LBS) MIN IN THE APPLICABLE NOMINAL HOLE SIZE AND A PLATE THICKNESS OF 1.8mm.
 3. SHEET METAL THICKNESS RANGE: 0.60mm - 6.65mm
 4. APPLICABLE HOLE SIZE:
 - A. 6.5mm +0.5/- 0.4
 - B. 6.35mm +/- 0.25 HEX
 5. CABLE TIE MIN LOOP TENSILE STRENGTH: 225 NEWTONS (50 LBS)
 6. BUNDLE RANGE: 2.0mm TO 50.0mm
 7. MAXIMUM PERCENT REGRIND PERMISSIBLE: 25%
 8. MAX ALLOWABLE FLASH OR MISMATCH TO BE: 0.25mm



MATERIAL	COLOR
PA66HIRHS	GRAY
PA66HIRHS	BLACK
PA66HIRHS	NATURAL
PA46	BROWN

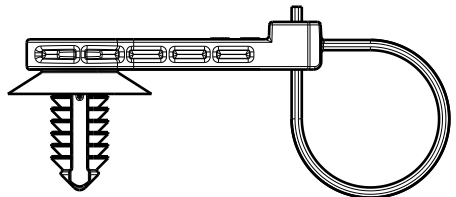

ASSEMBLY VIEW
SCALE 1:1

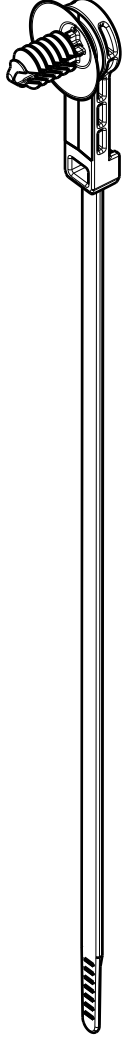

ISOMETRIC VIEW

Material SEE CHART COLOR: SEE CHART	Units millimeters	The copyright of this drawing is reserved by HellermannTyton. It is issued on condition that it is not reproduced, copied or disclosed to a third party, either wholly or in part, without the consent of HellermannTyton.	Drawn SJA 6/14/11	Article/Type-No T50ROSFT6SO25B	Scale 3:4	
	Tolerance defined on each dimension		Approved KVH 11/19/12	Title T50ROS WITH 25mm OFFSET AND FT6 FIR TREE (B-SERIES)	Project Number 11-0572	
			HellermannTyton North America Web: www.hellermann.tyton.com		Drawing-No PRODUCTION : Phase	Format AH
					11-0572-001-CSU	